



SOUTHWARK METAL MANUFACTURING COMPANY

Philadelphia, PA • Greenville, SC • Indianapolis, IN • Southaven, MS • Fremont, NE • Caldwell, ID

Corporate Headquarters: 2800 Red Lion Road, Philadelphia PA 19114

tel: (800) 523-1052 • fax (800) 722-2076 • www.southwarkmetal.com

SUBMITTAL DRAWING

**AIR-TITE TAKEOFF with DAMPER
(MODEL NO:ATD)**

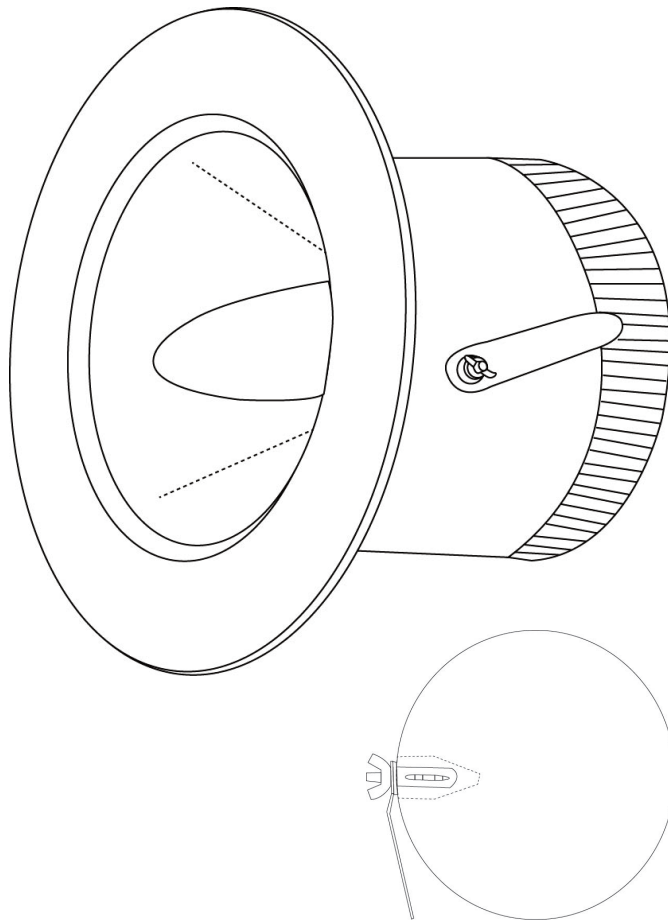

Collar Diameter	Gasket Diameter
4"	6 3/4"
5"	7 3/4"
6"	8 3/4"
7"	9 3/4"
8"	10 3/4"
9"	11 3/4"
10"	12 3/4"
12"	14 3/4"
14"	16 3/4"
16"	18 3/4"
18"	20 3/4"
20"	22 3/4"

NOTES

- Material: Hot Dipped Galvanized Steel per ASTM A653 CS Type B
- Available in 24, 26, or 28 gauge
- Available collar sizes 4" through 20"
- 5 3/4" tube length
- 1 1/2" crimp length
- Damper: 26 gauge with 18 gauge handle secured with wingnut with locking handle
- Gasket 1 1/2" wide and 1/8" thick; made with high tack adhesive-coated neoprene foam
- 4 pre-drilled screw holes
- Pressure rating: +/- 4" w.g.

JOB NAME: _____
 LOCATION: _____
 ARCHITECT: _____
 ENGINEER: _____
 CONTRACTOR: _____

DATE: 7/17/13 SW-ATDGVL SD-0088

Air-Tite Takeoff with Damper
 MODEL NO: ATD